

HME 410-1/-3

Headsets mit 10-poligen Spezial-Steckern

Bedienungsanleitung

Bügel auseinanderklappen.

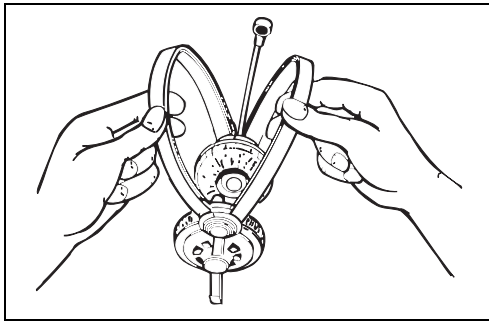

Headset aufsetzen.

Mikrofon so ausrichten, dass es sich dicht neben dem Mundwinkel befindet (Abstand ca. 2 cm).

Hinweis:

Der Mikrofonarm ist um 350° schwenkbar.

Das Mikrofon kann so links- oder rechtsseitig getragen werden.

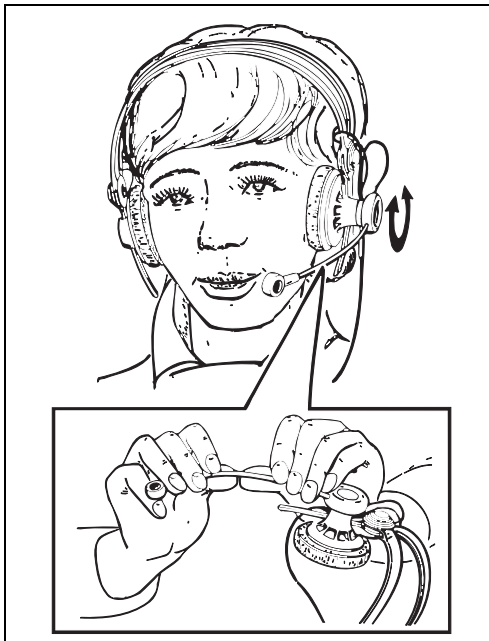

Für einohriges Hören Hörersystem nach hinten schwenken.

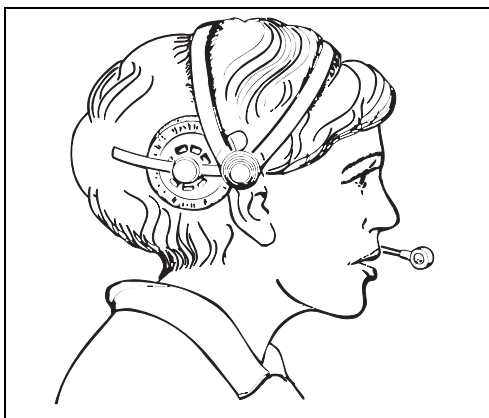

Technische Daten

Kopfhörer	Wandlerprinzip Übertragungsbereich Impedanz Kennschalldruckpegel (1 kHz, 1 mW) Andruckkraft	dynamisch 20 – 18,000 Hz 600 Ω pro System 100 dB ± 3 dB ca. 2,5 N
Mikrofon	Wandlerprinzip Übertragungsbereich Freifeld-leerlauf-Übertragungsfaktor Elektrische Impedanz (1 kHz) Min. Abschlussimpedanz Geräuschspannungsabstand nach DIN 45590 Versorgungsspannung Verstärker / Mikrofon Aussteuerbarkeit	Back-Elektret-Kondensatorkapsel, geräuschkompensiert 100 – 3,400 Hz 10 mV/Pa ± 1,5 dB ca. 1 kΩ 4,7 kΩ ≥ 64 dB 3,5 – 15 V / ca. 200 μA k = 1 % bei ca. 125 dB / U _B = 9 V
Verstärker	Betriebsspannung Aussteuerbarkeit Verstärkung (20 mA) R _i = 350 Ω Rauschspannung nach DIN 45405	± 12 V / ca. 15 mA k = 1 % bei U _{in} = 650 mV ca. 18 dB ca. 150 μV
Allgemein	Stecker Kabellänge Gewicht ohne Kabel und Verstärker Temperaturbereich Klimafestigkeit	410-1: Typ FFP-3S-310 410-3: Typ FGG-1B-310 ca. 1,8 m 130 g Lagerung: –20 °C bis +70 °C Betrieb: –10 °C bis +60 °C Lagerung bis +40 °C und 90 % relative Feuchte

Schaltbild
HME 410-1

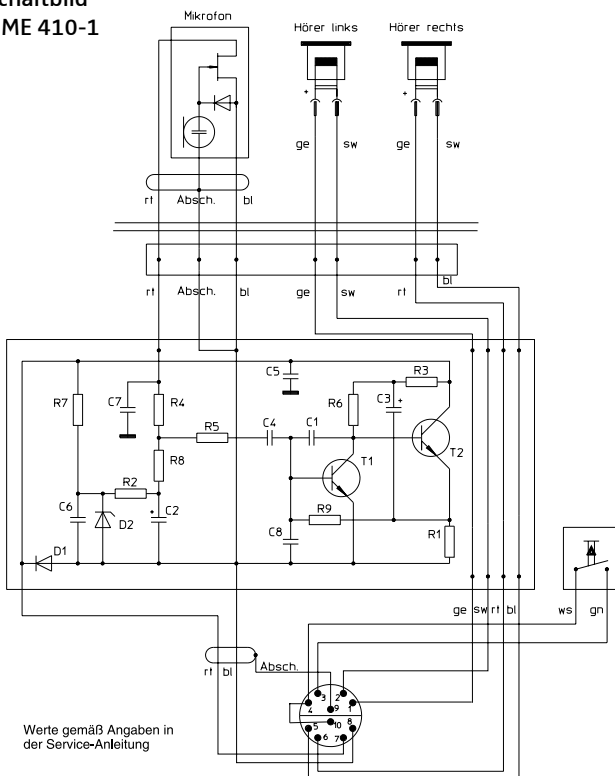

Werte gemäß Angaben in der Service-Anleitung

HME 410-3

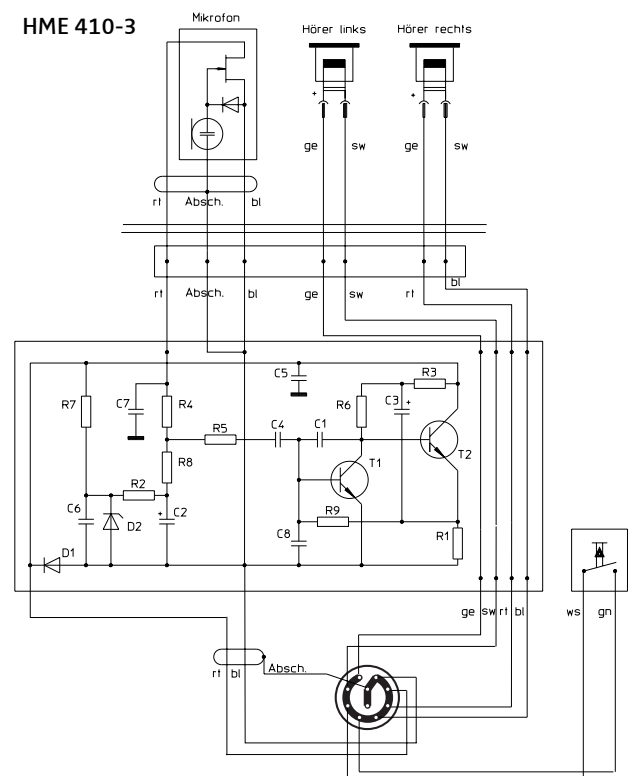

HME 410-1/-3

Headsets with 10-pin special connectors

Instructions for use

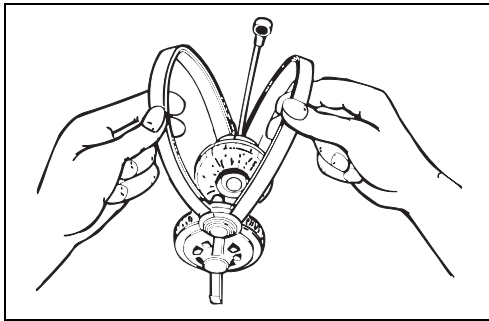

Adjust the two-piece headband.

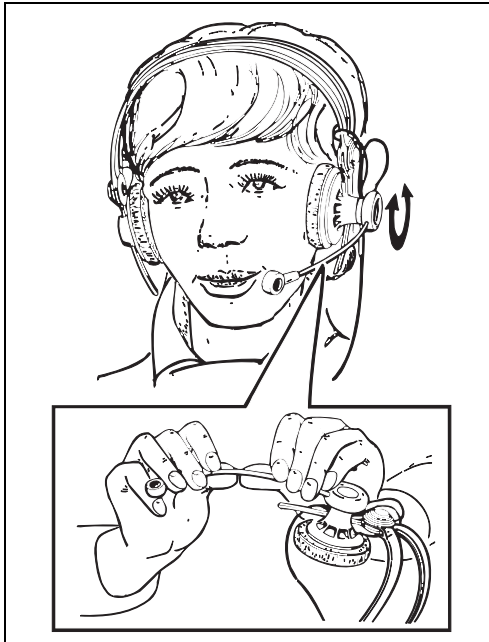

Put on the headset.

Position the microphone so that it is placed at the corner of the mouth (distance approx. 2 cm).

Note:

The microphone boom can be turned through 350° and thus be worn on either side.

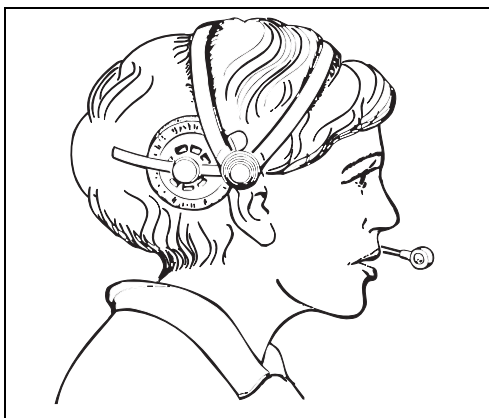

For single-sided listening, flip away one earcup.

Specifications

Headphones	Transducer principle Frequency response Impedance Characteristic SPL (1 kHz, 1 mW) Contact pressure	dynamic 20 – 18,000 Hz 600 Ω per side 100 dB ± 3 dB approx. 2.5 N
Microphone	Transducer principle Frequency response Sensitivity (free field, no load) Electrical impedance (1 kHz) Min. terminating impedance Signal-to-noise ratio as per DIN 45590 Supply voltage for amplifier / microphone Dynamic range	back-electret condenser mic capsule, noise-compensated 100 – 3.400 Hz 10 mV/Pa ± 1.5 dB approx. 1 kΩ 4.7 kΩ ≥ 64 dB 3.5 – 15 V / approx. 200 μA THD = 1 % at approx. 125 dB / U _B = 9 V
Amplifier	Operating voltage Dynamic range Gain (20 mA) R _i = 350 Ω Noise voltage as per DIN 45405	± 12 V / approx. 15 mA THD = 1 % at U _{in} = 650 mV approx. 18 dB approx. 150 μV
General	Connectors Cable length Total weight without cable and amplifier Temperature range Climatic rating	410-1: Typ FFP-3S-310 410-3: Typ FGG-1B-310 approx. 1.8 m 130 g storage: –20 °C to +70 °C operation: –10 °C to +60 °C storage at up to +40 °C and 90 % relative humidity

Circuit Diagram

HME 410-1

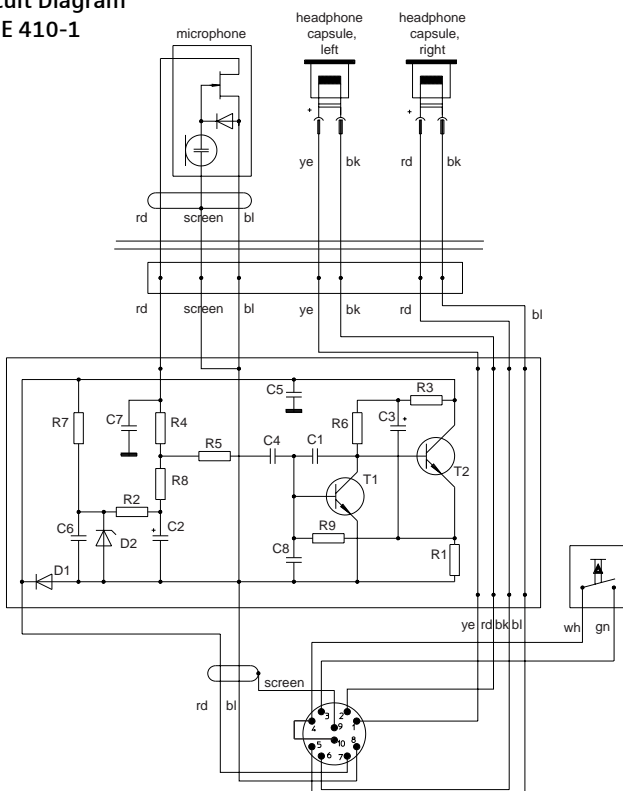

HME 410-3

